

KA 34



Performance features

- » Can be used for openings for smoke exhaust; D+H Euro SHEV in accordance with EN 12101-2; and for daily ventilation
- » With motor electronics controlled via microprocessor
- » High-speed function (HS) for especially fast opening windows in case of fire (SHEV)
- » Special chain stabilisation
- » Pressure applications up to 700 mm, application tension stroke lengths >1000 mm possible
- » Relief of pressure on window gasket after closing process
- » Programmable drive functions and different drive parameters
- » Running speed in CLOSED direction decreases to 5 mm/s (passive closing edge protection)
- » Time-controlled reversing when an obstacle is detected in the CLOSED direction (active closing edge protection)

Potential drive options



You can find the explanations for the icons on the last page

Pressure load diagram

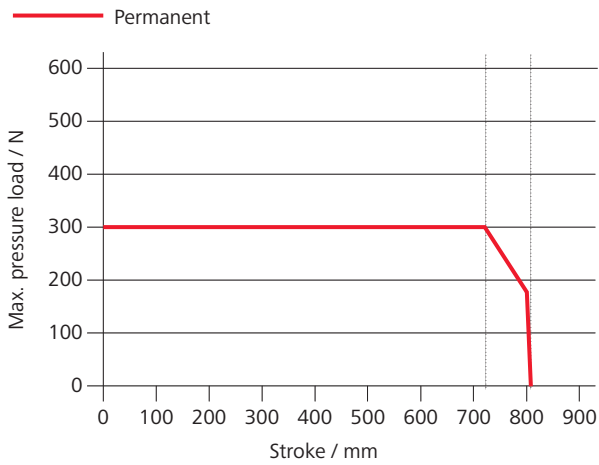

Dimensions

All specifications in mm

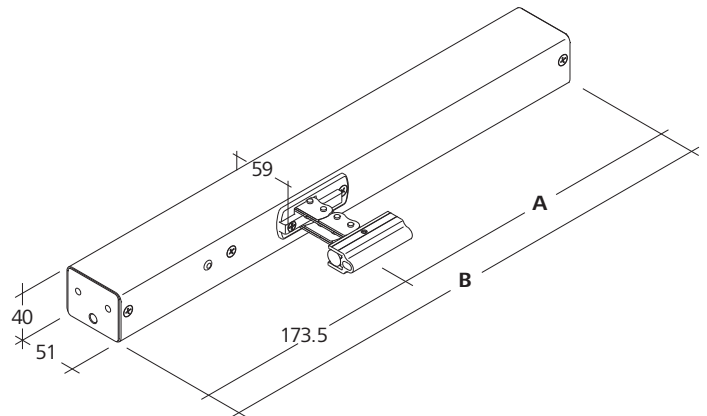

Technical data

Supply	24 V DC / ±15 % / 1 A
Duty cycle	30 %
Force of pressure	300 N
Tensile force	300 N
Nominal locking force	2000 N
Service life	20000 double strokes *
OPEN running speed	11.8 mm/s
OPEN running speed - SHEV	12.2 mm/s
CLOSED running speed	11.8 mm/s
Type of protection	IP 32
Emission sound pressure level	LpA ≤ 70 dB(A)
Temperature range	-5 °C ... +75 °C
Fire resistance	B300 (30 min / 300 °C)
Housing	Aluminium
Surface	Powder-coated
Colour	White aluminium (~ RAL 9006)
Connection	2.5 m silicone cable

* For vertical use, please consult with D+H Sales!

Approvals / Certificates

Find out about permission details from your D+H Partner



G 503007



5014068.18005-1



Article also available with the following permissions under other article numbers. Technical data may deviate.



Design

Type	Art. No.	Stroke	Dimension A	Dimension B	Weight	Remark
KA 34/350	26.000.10	350 mm	247.5 mm	421 mm	1.60 kg	
KA 34/500	26.000.15	500 mm	322.5 mm	496 mm	1.90 kg	
KA 34/600	26.000.20	600 mm	372.5 mm	546 mm	2.20 kg	
KA 34/700	26.000.25	700 mm	422.5 mm	596 mm	2.40 kg	
KA 34/800	26.000.30	800 mm	472.5 mm	646 mm	2.60 kg	Observe pressure load diagram!
KA 34/1000	26.000.35	1000 mm	576.5 mm	750 mm	3.00 kg	Observe pressure load diagram!
KA-PLP	26.000.00					Variable equipment possible

Brackets are not included and have to be ordered separately.



HS "High-Speed"

In the case of SHEV, the high-speed function is used for reliably reaching the defined end position in 60 s. In daily ventilation mode, the drive runs quietly and quickly, as usual.



Function programming

Option for customised configuring of drive parameters (e.g. stroke) via software and associated service tools for drives equipped with PLP, BSY or BSY+ electronics.



BRV signal

Acknowledgement from the drive, via a control cable, to confirm that it has been completely extended or retracted. When used with the AT 41 and ERM 44 modules, this signal is sent to the central building control system, the modules themselves, or to the lock drive. The BRV signal is not isolated.



ACB (Advanced Communication Bus)

Enables direct bus communication between the controller and the drive for, for example, control with perfect positioning or drive feedback. Communication is via the open source Modbus protocol, and it enables the drive to be combined with an ACB-capable control panel or enables it to be directly connected to higher-level controllers such as a building management system.



BSY+ (synchronisation of drives)

In addition to providing the same synchronisation function as BSY, BSY+ enables different components in the window to communicate with each other. For example, the chain drives, during synchronous operation, or the window and lock drives (e.g. FRA 11 BSY+ or VLD-BSY+).



SGI signal (position reporting)

In combination with the D+H servo plug-in unit SE 622, the drives can be controlled with perfect positioning.



SKS (closing edge protection)

Drive option, which enables an anti-trap strip or presence detector to be connected directly to the drive (terminal resistor 5.6 kΩ).



Audible signal (corresponding to protection class)

AS2 corresponding to "Protection class 2" in accordance with ZVEI risk assessment through an audible warning signal in the "CLOSED" running direction. AS3 corresponding to "Protection class 3" in accordance with ZVEI risk assessment, in addition to AS2, stops the drive for 11 s with a remaining stroke of 28 mm.



End position message (OPEN / CLOSED)

Drive feedback via an integrated isolated switching contact. This happens if the chain / rack and pinion has moved completely out or in.



Mechanical adjustment

Drive option for adjusting the overall length or design (e.g.: centred chain outlet).



SBD side bow chain

Drive chain with rigid backing, bends in the direction of the hinge. Drive is fixed in place (not rotatable).



SBU side bow chain

Drive chain with rigid backing, bends in the direction of the hinge. Drive is fixed in place (not rotatable).